

ROCKS-e

In brief



O P E L

Introduction

This Owner's Manual provides you with all the necessary information to enable you to drive your vehicle safely and efficiently.

Some functions are only operational when the ignition is switched on or when the electric motor is ready.

Make sure your passenger is aware of the possible risk of accident and injury which may result from improper use of the vehicle.

You must always comply with the specific laws and regulations of the country that you are in. These laws may differ from the information in this Owner's Manual.

Disregarding the description given in this manual may affect your warranty.

When this Owner's Manual refers to a workshop visit, we recommend your Opel Service Partner.

All Opel Service Partners provide first-class service at reasonable prices. Experienced mechanics trained by Opel work according to specific Opel instructions.

Danger, Warnings and Cautions

⚠ Danger

Text marked **⚠ Danger** provides information on risk of fatal injury. Disregarding this information may endanger life.

⚠ Warning

Text marked **⚠ Warning** provides information on risk of accident or injury. Disregarding this information may lead to injury.

Caution

Text marked **Caution** provides information on possible damage to the vehicle. Disregarding this information may lead to vehicle damage.

Symbols

Page references are indicated with ⇨. ⇨ means "see page".

We wish you many hours of pleasurable driving.

Your Opel Team

Keys

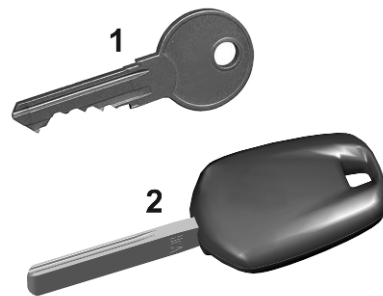

- 1 : Key to lock / unlock doors
- 2 : Key to switch motor on / off

Front doors



Caution

Do not open the door when moving.

Unlock / lock

To unlock / lock the vehicle, insert the key into the lock and turn it clockwise / anticlockwise.

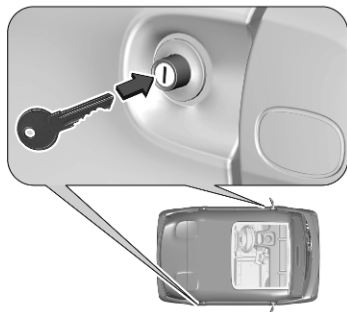

Note

The vehicle can only be unlocked or locked from the outside.

Opening

After unlocking, press the door lock to open the door.

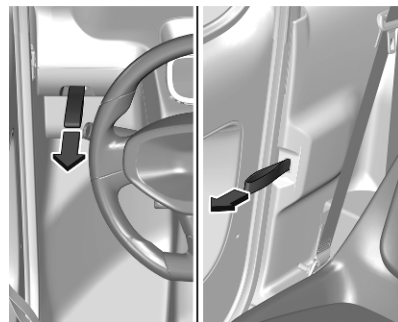

To open the door from the inside, pull the opening strap.

Closing

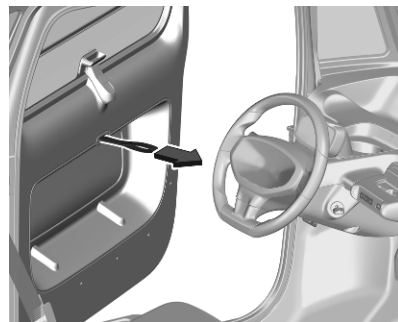

To close the doors from the inside, pull the closing strap of the respective door.

Mirrors

The door mirrors are adjusted and folded manually.

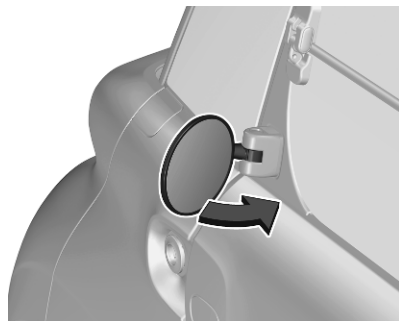

Move the door mirrors in several directions in order to obtain the best visibility.

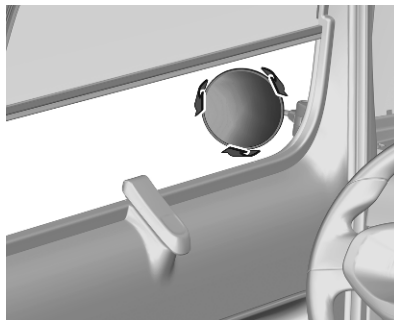

Windows

The windows consist of a fixed upper part and a moveable lower part.

Opening

Caution

When opening the window, ensure that it is properly locked before driving off, as it may unlock or lower while driving.

At first, press the locking handle to release the window.

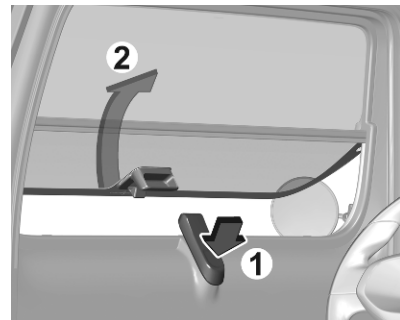

Then, lift the window as far as possible to keep it fully open.

Closing

Caution

Keep a close watch on the windows when closing them. Ensure that nothing becomes trapped in them as they move.

To unlock the window, pull the window from the outside, then lower it until it locks in place.

Press against the window to check if it is locked.

Seat adjustment

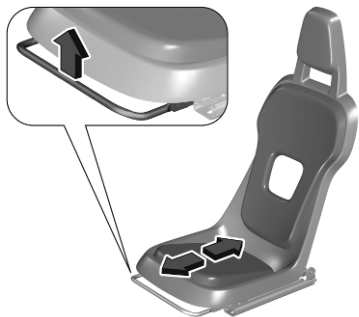

Note

Only the driver's seat is adjustable.

Pull handle, slide seat, release handle. Try to move the seat back and forth to ensure that the seat is locked in place.

Seat belts

⚠ Warning

The lower part of the strap must be positioned as low as possible on the pelvis.

The upper part must be positioned in the hollow of the shoulder.

In order to be effective, a seat belt must:

- be tightened as close to the body as possible.
- be pulled in front of you with a smooth movement, checking that it is not twisted.
- only be used to secure one person.
- not show signs of tearing or fraying.
- not be changed or modified, in order to avoid affecting its performance.

⚠ Warning

Use a suitable child restraint system if the passenger is less than 12 years old or shorter than one and a half metres.

Make sure that the seat belt is correctly positioned and tightened.

Never use the same seat belt to secure more than one child.

Never carry a child on your lap.

For more information on restraint systems, refer to the corresponding section.

⚠ Warning

Have the seat belts checked regularly by a qualified workshop, particularly if the straps show signs of damage.

Clean the seat belt straps with soapy water or a textile cleaning product, sold by dealers or qualified workshops.

The seat belts are equipped with an inertia reel which allows the strap length adjust to your shape automatically.

The seat belt returns to its storage automatically when it is not used.

Before and after use, ensure that the seat belt is reeled in correctly.

Fasten

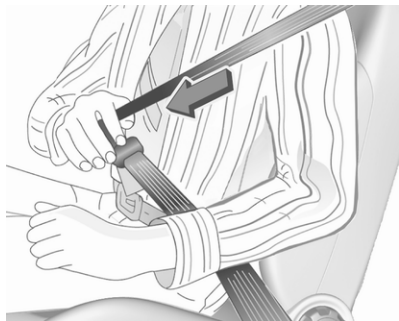

Withdraw the belt from the retractor, guide it untwisted across the body and insert the latch plate into the buckle. Make sure the belt fits tightly to the body while driving.

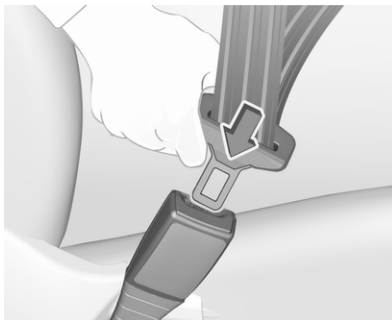

Loose or bulky clothing prevents the belt from fitting snugly. Do not place objects such as handbags or mobile phones between the belt and your body.

⚠ Warning

The belt must not rest against hard or fragile objects in the pockets of your clothing.

Unfasten



To release the belt, press the red button on the belt buckle. Guide the seat belt as it is reeled in.

Using seat belts while pregnant



⚠ Warning

The lap belt must be positioned as low as possible across the pelvis to prevent pressure on the abdomen.

Child restraint systems

Note

The regulations on carrying children are specific to each country. Refer to the legislation in force in your country.

⚠ Warning

An incorrectly installed child seat in a vehicle compromises the child's safety in the event of an accident.

Ensure that there is no seat belt or seat belt buckle under the child seat, as this could destabilise it.

Remember to fasten the seat belts or the child seat harness keeping the slack relative to the child's body to a minimum, even for short journeys.

Check that the seat belt is properly tightened over the child seat and that it holds the child seat firmly against the vehicle seat. For child seats with a support leg, ensure that the support leg is in firm and steady contact with the floor.

⚠ Warning

The chest part of the seat belt must be positioned on the child's shoulder without touching the neck.

Ensure that the lap part of the seat belt passes correctly over the child's thighs.

Use a booster seat with a backrest, equipped with a belt guide at shoulder level.

⚠ Warning

As a safety measure, do not leave:

- A child alone and unsupervised inside the vehicle.
- A child or an animal in a vehicle exposed to the sun with the windows closed.
- The keys inside the vehicle.

For maximum safety, please observe the following recommendations:

- In accordance with European regulations, all children under the age of 12 or less than 1.5 m tall must travel in approved child seats appropriate for their weight, on seats fitted with a seat belt.
- Do not use forward facing child restraint systems when the child's weight is below 13 kg.

Child restraint installation locations

In accordance with European regulations, this table indicates the options for installing child restraint systems secured using the seat belt and universally approved in relation to the weight of the child.

Weight of the child / indicative age

Child restraint system categories	Weight of the child / indicative age			
	Under 13 kg (groups 0 ¹⁾ and 0+): Up to about 1 year old	From 9 to 18 kg (group 1): From about 1 to 3 years old	From 15 to 25 kg (group 2): From about 3 to 6 years old	From 22 to 36 kg (group 3): From about 6 to 10 years old
Universal belted child restraint system ²⁾	U	UF	UF	UF

1) Group 0: birth to 10 kg. Carrycots and "car" infant carriers cannot be installed on the front passenger seat.

2) Universal child seat: child seat that can be installed in all vehicles using the seat belt.

U : Seat position suitable for installing a child restraint system secured using the seat belt and universally approved for rearward facing and/or forward facing use.

UF : Seat position suitable for installing a child restraint system secured using the seat belt and universally approved for forward facing use.

Storage compartments

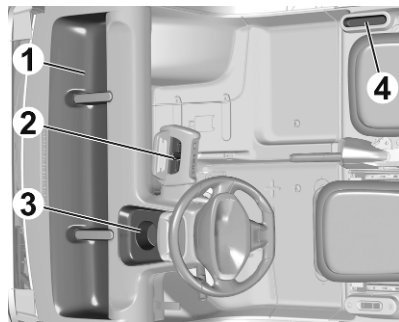

- 1 : Open triple-compartment storage unit
- 2 : Mobile device holder
- 3 : Driver's storage compartment / housing for Bluetooth speaker
- 4 : Passenger storage compartment

Instrument panel overview

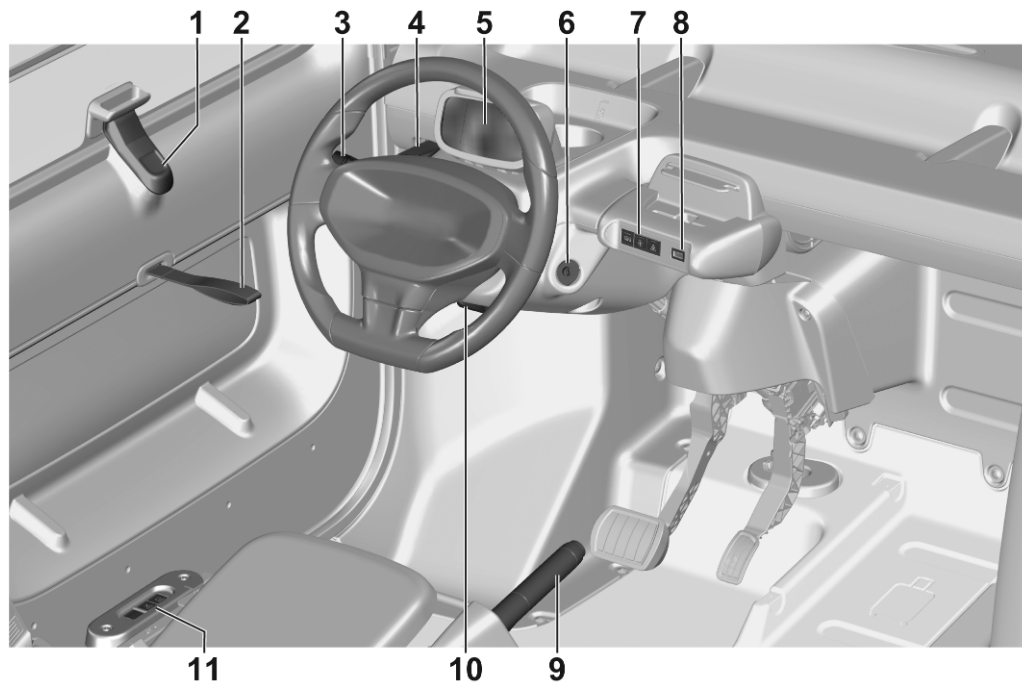

- 1 Window locking handle 5
- 2 Closing strap 4
- 3 Turn lights 18
- Windscreen wiper and washer 14
- Horn 13
- 4 Opening strap 4
- 5 Driver Information Centre 15
- 6 Ignition switch 19
- 7 Heating and ventilation system 18
- Hazard warning flashers 18
- 8 USB port 14
- 9 Parking brake 21
- 10 Steering wheel adjustment . . 13
- 11 Electric drive unit 20

Steering wheel adjustment

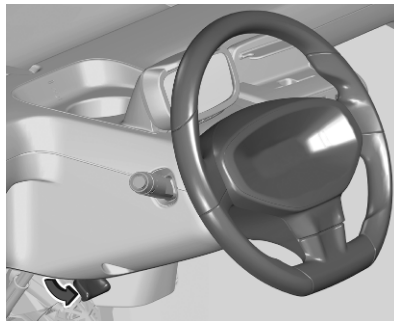

Unlock the lever, adjust the steering wheel, then engage the lever and ensure it is fully locked.

Do not adjust the steering wheel unless the vehicle is stationary and the steering wheel lock has been released.

Horn

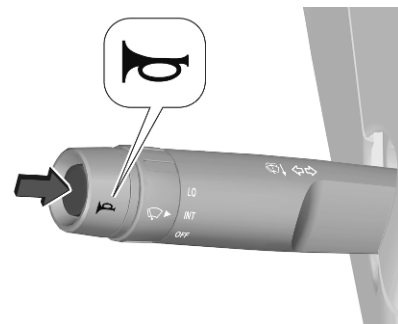

Press the button.

Windscreen wiper and washer

Windscreen wiper

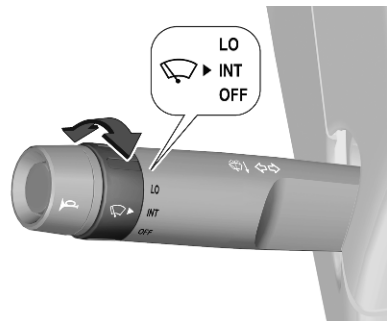

LO : continuous wiping
INT : interval wiping
OFF : off

Do not use if the windscreen is frozen.

Windscreen washer

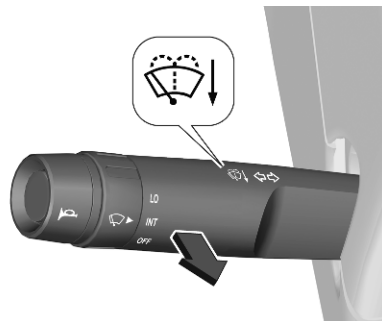

Pull lever. Washer fluid is sprayed onto the windscreen and the wiper wipes a few times.

Washer fluid ⇄ 25.

Power outlets

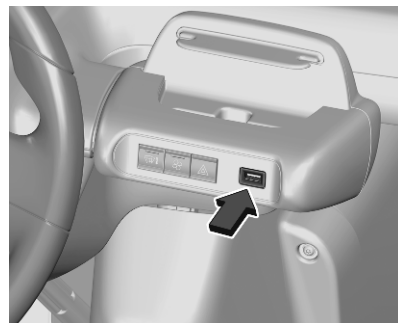

The USB port can be used to charge a portable device.

Driver Information Centre

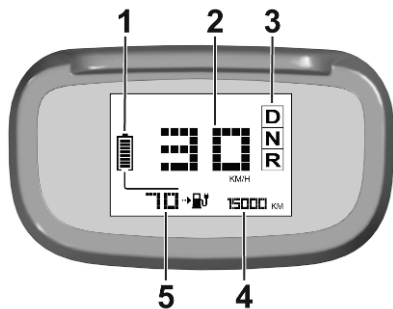











- 1 charge level of the high voltage battery
- 2 speedometer
- 3 selected drive mode
- 4 odometer
- 5 driving range or remaining charging time





The overview table indicates what to do, when a control indicator illuminates or flashes.

Some control indicators will be accompanied by a warning chime.

Warning lights, gauges and indicators

	STOP	The vehicle must be stopped. A serious fault has been detected. Switch the ignition off and seek the assistance of a workshop.
	Parking brake	The parking brake is applied or not properly released.
	Parking brake	The charging cable is connected and the parking brake is released. Charging or starting the vehicle is not possible. Apply the parking brake or disconnect the charging cable.
	Braking	The vehicle must be stopped. The brake fluid level has dropped significantly. Switch the ignition off, check for the presence of a leak and seek the assistance of a workshop.
	Service	One or more major faults have been detected. Seek the assistance of a workshop.
	High voltage battery	The high voltage battery has reached the first alert threshold. Charge the vehicle as soon as possible.
	High voltage battery	The high voltage battery has reached the second alert threshold. The vehicle's power decreases rapidly. The vehicle must be charged.
	Limited power	A drop in performance in the drive train due to a fault has been detected. Seek the assistance of a workshop.
	High voltage battery	The high voltage battery's temperature is too high. Seek the assistance of a workshop.
	Turn lights	The left or right turn lights are activated.

	Hazard warning flashers	The hazard warning flashers are activated.
	Brake pedal	Insufficient pressure or no pressure detected on the brake pedal for changing the direction of travel. Depress the brake pedal to select or change the direction of travel.
READY	Vehicle switched on	The light remains on and will extinguish when the vehicle is switched off and the passengers have left the vehicle.
	Charging cable connected	The charging cable is connected to an electrical outlet.

Automatic light control

When the ignition is switched on, all the lights come on (sidelights, low beam and number plate light).

When the ignition is switched off, all the lights go out.

Hazard warning flashers



Operated by pressing .

The hazard warning flashers can operate with the ignition off.

Turn lights

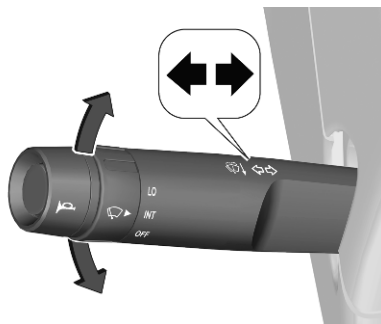

up : right turn lights
down : left turn lights

A resistance point can be felt when moving the indicator lever.

Constant flashing is activated when the indicator lever is being moved beyond the resistance point. It is deactivated when the steering wheel is moved in the opposite direction or the indicator lever is manually moved back to its neutral position.

To activate three flashes, tap the indicator lever briefly without passing the resistance point.

Heating and ventilation system



To activate or deactivate heating / demisting, press .

The demisting system reduces misting on the windscreen. If the side windows are misted up, wipe them with a clean, soft cloth.

The demisting of the windscreen can take up to 15 minutes or more.



To activate or deactivate ventilation, press .

Driving on wet roads

Caution

Do not drive on flooded roads as this could seriously damage your vehicle's motor and electrical system.

If driving on a flooded road is not avoidable:

- Check that the depth of water does not exceed 10 cm, taking account of waves that might be generated by other vehicles.
- Drive as slowly as possible without stalling. In all cases, do not exceed 10 km/h.
- Do not stop and do not switch off the motor.

When leaving the flooded road, as soon as safety conditions allow, make several light brake applications to dry the brake discs and pads. If in any doubt about the conditions of the vehicle, consult a dealer or qualified workshop.

Starting the engine

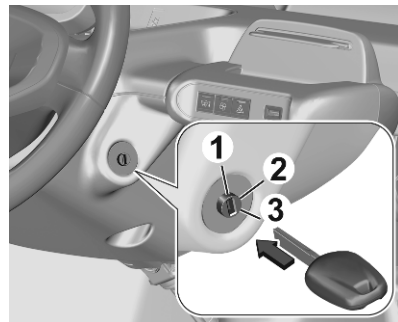

1. Insert the key and turn the key to position 2 to switch on the ignition.
When the ignition is switched on, the Driver Information Centre illuminates, all lights come on and the steering column is unlocked.
2. Depress the brake pedal.
Do not depress the accelerator pedal.
3. Turn the key to position 3.
N is engaged and **READY** illuminates in the Driver Information Centre.

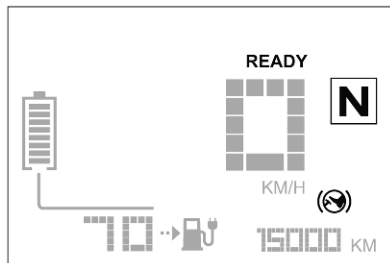

If a drive position is selected without any pressure on the pedals for 5 seconds, a warning chime will sound.

Press **D** or **R** on the drive selector, then accelerate or brake.

Note

In order to protect the drive chain, a slight decrease in performance may be observed at low temperatures or during prolonged use of maximum power.

Switching off

1. Depress the brake pedal.
2. Apply the parking brake.

3. Turn the key to position 1.
4. Release the brake pedal.

A few seconds after the ignition is switched off, the Driver Information Centre goes off, all the lights go out and the steering column is locked automatically.

Electric drive unit

The vehicle uses an electric drive unit with a 1-gear transmission.

The drive mode, neutral and the reverse gear are selectable via buttons next to the driver's seat.



D : drive mode

N : neutral

R : reverse gear, engage only when the vehicle is stationary

Drive mode D

To shift into **D**, the brake pedal has to be depressed.

Caution

If the vehicle seems to accelerate slowly or not respond when you try to go faster, do not continue your journey. The electric drive unit could be damaged. Consult a workshop as soon as possible.

Neutral N

In this mode, the propulsion system does not transfer torque to the wheels. To restart the propulsion system when the vehicle is already moving, use **D** only.

Reverse gear R

To shift into and out of **R**, the vehicle must be at standstill and the brake pedal has to be depressed.

Caution

Shifting into **R** while the vehicle is moving forward could damage the electric drive unit. Only shift into **R** after the vehicle has been stopped.

Parking brake**⚠ Warning**

Before leaving the vehicle, check the parking brake status. The control indicator (P) must illuminate constantly.

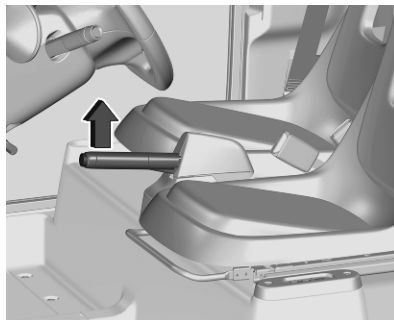
**⚠ Warning**

Always apply the parking brake firmly without operating the release button, and apply as firmly as possible on a downhill or uphill slope.

When parking on a slope, turn the front wheels towards the kerb.

To release the parking brake, pull the lever up slightly, press the release button and fully lower the lever.

To reduce the operating forces of the parking brake, depress the foot brake at the same time.

Charging

The high voltage battery stores the energy needed to operate the electric motor and the vehicle's electrical cabin components. It will be discharged during use and must therefore be regularly charged. There is no need to wait for the high voltage battery to fall to its reserve level before recharging.

The driving range can vary depending on the use of the electrical cabin components, the driving style, the route, and the age of its components.

The charging performance depends on the temperature of the high voltage battery.

When the temperature of the high voltage battery is above 5 °C, the charging process takes up to 3.5 hours.

When the temperature of the high voltage battery is below 5 °C, the charging process could take up to 6 hours.

Caution

Charging is not possible if the temperature of the high voltage battery is below -5 °C.

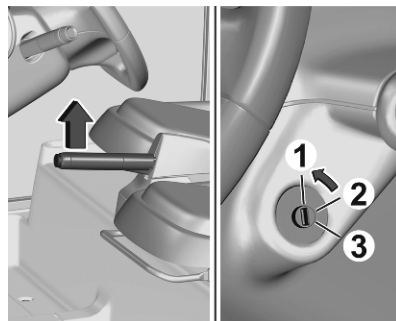

Before charging, park the vehicle as close as possible to a domestic electrical outlet, apply the parking brake and switch off the engine.

Caution

Do not use an extension cable, a multi-plug connector, a conversion adaptor or a damaged power outlet.

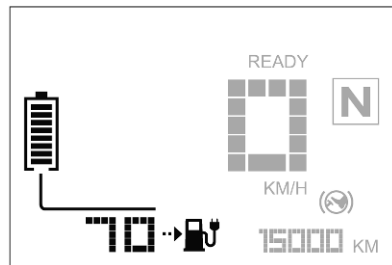

The charge level of the high voltage battery and the remaining driving range will be displayed in the Driver Information Centre.



The charging cable is permanently attached to the vehicle. It is stored inside the passenger door frame.

To charge the high voltage battery, unfurl the charging cable fully.

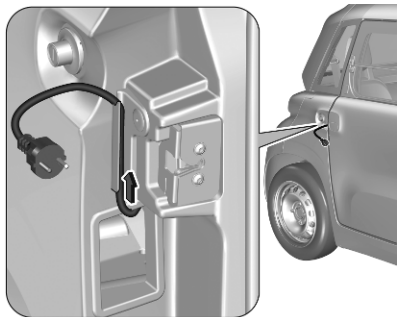

Close the passenger door and ensure that the charging cable passes through the guide hole in the door frame into the handle recess.

Connect the charging cable to a domestic electrical outlet.

The charging procedure stops automatically when the high voltage battery is fully charged.

The charging process can be interrupted at any time.

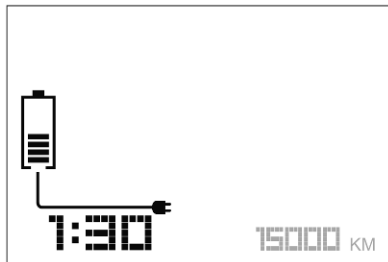

The remaining charging time is displayed in the Driver Information Centre. When the charging process is completed, **0:00** will be displayed in the Driver Information Centre or the Driver Information Centre will be switched off.

After charging, disconnect the charging cable, open the passenger door and store the cable in its housing.

Vehicle storage

Caution

To immobilise the vehicle for more than a month, park the vehicle at a weatherproof location where the temperature is between 0 °C and 40 °C.

The charging level of the high voltage battery must be around 50%.

Disconnect the connector unit.

Remove the F7 fuse in fuse box 1.

Disconnect the vehicle battery.

Vehicle battery ⇨ 26.

Fuses ⇨ 30.

Performing work

⚠ Warning

Before doing any works, switch off the ignition, apply the parking brake, check that the Driver

Information Centre is off and that the charging cable is not connected.

Removing the front or rear bumper

Before the rear bumper can be removed, the number plate light needs to be removed as described below.

1. Pass the number plate light's suspended wiring loom behind the bumper.

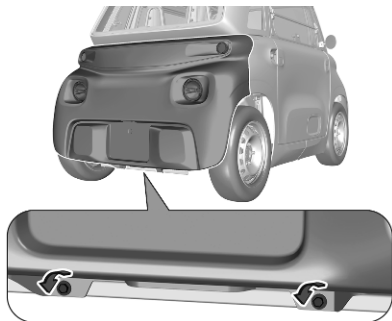

2. Remove the two lower fixing screws from the frame.

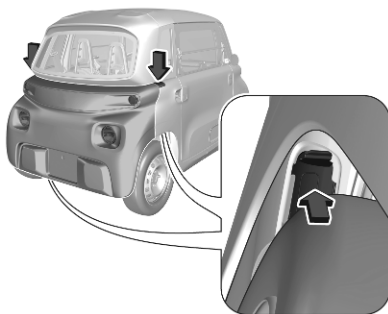

3. Remove the two upper access flaps from the wings.

Pass an arm under a wing and lift it up.



4. Remove the two upper side fixing screws from the flaps.

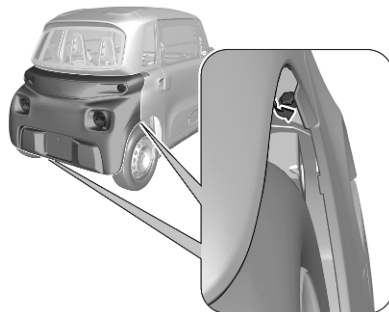

5. Remove the two lower side fixing screws from the wheel arches.
6. Pull the bumper horizontally for about 10 cm until the attachment points come away.

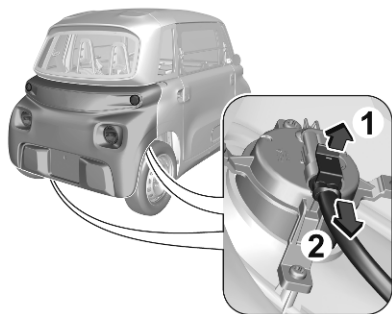

7. Disconnect the turn light wiring looms.

Refitting the front or rear bumper

1. Bring the bumper close to the frame.
2. Connect the turn light wiring looms.
3. Place the bumper in position and push the bumper horizontally until the attachment points clip into place.
4. Screw the two upper side fixing screws into the flaps.
5. Screw the two lower side fixing screws into the wheel arches.

6. Screw the two lower fixing screws into the frame.
7. Clip the two upper access flaps to the wings.

When the rear bumper is refitted, replace the number plate light.

Removing and refitting the number plate light

1. Lie down behind the vehicle in the middle of the rear bumper.
2. Pass an arm behind the bumper to reach the light above the foam shock absorber.
3. Pinch the fixing clip holding the light.
4. Push the light down while holding the fixing clip.
5. Disconnect the light from its wiring loom.
6. Leave the wiring loom dangling through the bumper.

To refit the number plate light, reconnect the light to the suspended wiring loom and replace the light into its housing by pressing it until it clips into place.

Washer fluid

The washer fluid tank is located behind the seats.

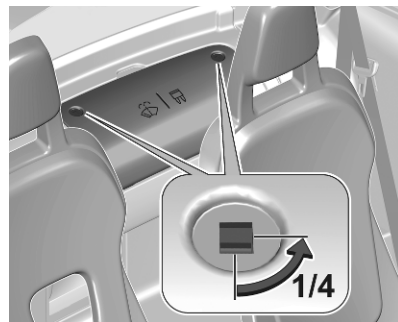

Turn both fixing screws a quarter turn and remove the access cover.

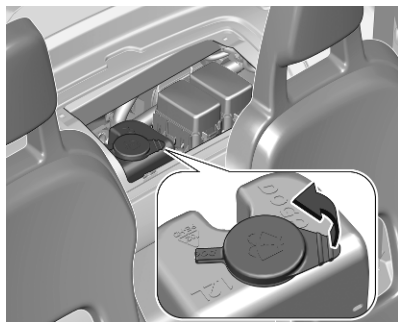

Remove the cap from the tank to top up.

The tank has a capacity of maximum 1 l.

Fill with clean water mixed with a suitable quantity of approved windscreen washer fluid which contains antifreeze.

Caution

Only washer fluid with a sufficient antifreeze concentration provides protection at low temperatures or a sudden drop in temperature.

Washer fluid ⇨ 33.

Brake fluid

⚠ Warning

Brake fluid is poisonous and corrosive. Avoid contact with eyes, skin, fabrics and painted surfaces.

To get access to the brake fluid tank, the front bumper needs to be removed ⇨ 23.

Caution

Before topping up, it is necessary to protect the electric motor in order to avoid any risks of brake fluid splashing onto it.

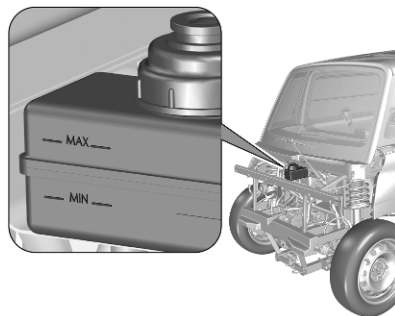

The brake fluid level must be between the **MIN** and **MAX** marks.

If fluid level is below **MIN** seek the assistance of a workshop.

Brake fluid ⇨ 33.

Vehicle battery

The vehicle battery is maintenance-free provided that the driving profile allows sufficient charging of the battery. Avoid the use of unnecessary electrical consumers.



Batteries do not belong in household waste. They must be disposed of at an appropriate recycling collection point.

Laying up the vehicle for more than four weeks can lead to battery discharge. Disconnect the clamp from the negative terminal of the vehicle battery.

Ensure the ignition is switched off before connecting or disconnecting the vehicle battery.

Removing the vehicle battery

⚠ Warning

Before doing any works, switch off the ignition, apply the parking brake, check that the Driver

Information Centre is off and that the charging cable is not connected.

To get access to the vehicle battery, the rear bumper needs to be removed
 ⇨ 23.

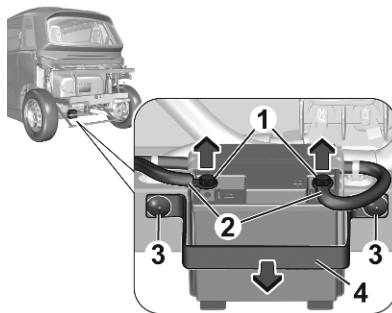

First, disconnect the negative terminal (left-hand side).

When the negative terminal is disconnected, disconnect the positive terminal (right-hand side).

Disconnect a terminal as follows:

1. Unscrew and remove the screw (1) from the clamp (2).
2. Remove the clamp (2) from the terminal.

⚠ Warning

Make sure that the disconnected clamps do not come into contact with the vehicle battery terminals.

When both terminals are disconnected, proceed as follows:

1. Unscrew the two fixing screws (3) on the vehicle battery's retainer brace (4).
2. Remove the retainer brace (4) and the vehicle battery.

Refitting the vehicle battery

1. Place the vehicle battery into its compartment.
2. Replace the retainer brace (4) and its two fixing screws (3).

Next, the terminals need to be reconnected. Reconnect the positive terminal (right-hand side) first.

When the positive terminal is reconnected, reconnect the negative terminal (left-hand side).

Reconnect a terminal as follows:

1. Insert the nut horizontally into the terminal's square housing.
2. Place the clamp (2) on top of the terminal.
3. Insert the screw (1) into the terminal and nut and screw tight.

Starting using another battery

If the vehicle battery is flat, the electric motor can be started using a backup battery (either external or from another vehicle) and jump leads or using a battery booster.

⚠ Warning

- Never start the electric motor by connecting a battery charger.
- Never use a 24 V or higher battery booster.

- Check beforehand that the backup battery has a nominal voltage of 12 V and a capacity at least equal to that of the discharged battery.
- The two vehicles must not be in contact with each other.
- Disconnect or turn off all electrical devices in both vehicles (portable devices, wipers, lights, etc.).
- Do not disconnect the positive terminal while the electric motor is switched on.

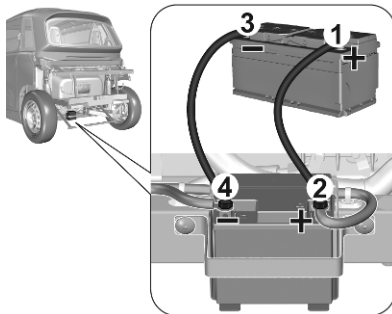

1. Connect the red cable to the positive terminal of the flat vehicle battery (2), then to the positive terminal of the backup battery (1) or booster.
2. Connect one end of the black cable to the negative terminal of the backup battery (3) or the booster (or to an earth point on the assisting vehicle).
3. Connect the other end of the black cable to the negative terminal of the flat vehicle battery (4).
4. When connected to an assisting vehicle, start the engine on the assisting vehicle and leave it running for a few minutes.
5. Turn the ignition key to start the disabled vehicle.
The high voltage battery takes over the supply to the 12 V circuit.
6. Wait for the assisting vehicle to return to idle.
7. Disconnect the jump leads in reverse order.
8. Leave the vehicle switched on for at least 30 minutes to allow the

high voltage battery to recharge the vehicle battery.

If the battery charge level in the high voltage battery is too low, connect the vehicle's charging cable.

Charging the vehicle battery using a battery charger

For optimum service life of the vehicle battery, it is essential to maintain an adequate level of charge.

In some circumstances, it may be necessary to charge the vehicle battery:

- When using the vehicle mainly for short journeys.
- If the vehicle is to be taken off the road for several weeks.

⚠ Warning

- Only use a charger compatible with lead-acid batteries and with a nominal voltage of 12 V.
- Follow the instructions provided by the manufacturer of the charger.
- Never reverse polarities.
- Disconnect the vehicle battery from the vehicle.
- Make sure the vehicle's charging cable is not connected at the same time.

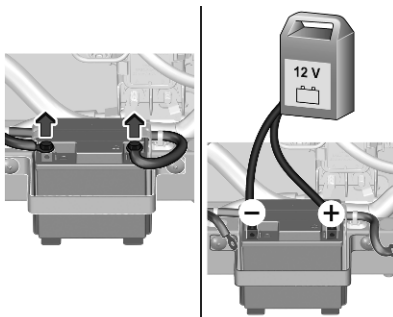

Before charging the vehicle battery using a battery charger, the vehicle battery needs to be disconnected from the vehicle.

To charge the vehicle battery using a battery charger, proceed as follows:

1. Switch the charger off before connecting the cables to the vehicle battery to avoid any dangerous sparks.
2. Ensure that the charger cables are in good condition.
3. Connect the red cable to the positive terminal on the vehicle battery.
4. Connect the black cable to the negative terminal on the vehicle battery.

At the end of the charging operation, switch the charger off before disconnecting the cables from the vehicle battery.

Wiper blade replacement

Caution

- Take care not to hold the arms at the jet locations.
- Do not release them while moving them. Risk of damaging the windscreen.

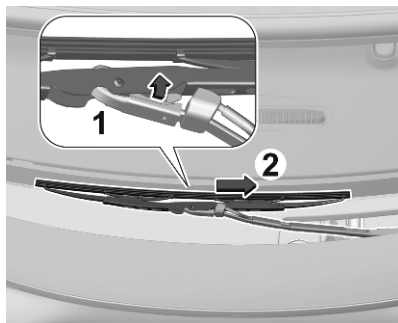

1. Grasp the wiper blade by its rigid part and pull it towards you as far as it will go.
2. While keeping the wiper arm raised, unclip the worn blade (1) and remove it (2).

3. While keeping the wiper arm raised, install the new blade and clip it into place.
4. Lower the arm carefully and support it until it reaches the windscreen.

Bulb replacement

All lights are designed as LEDs and cannot be changed.

Have lights repaired by a workshop in case of failure.

Fuses

Data on the replacement fuse must match the data on the defective fuse.

Before replacing a fuse, turn off the respective switch and the ignition.

A blown fuse can be recognised by its melted wire.

Caution

Do not replace the fuse until the cause of the fault has been remedied.

The fuse boxes are located behind the seats.

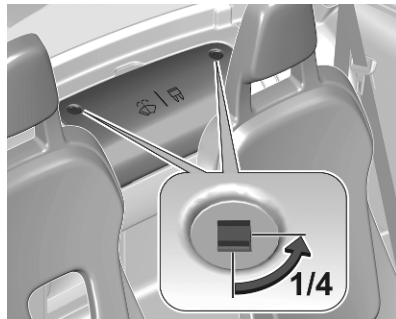

Turn both fixing screws a quarter turn and remove the access cover.

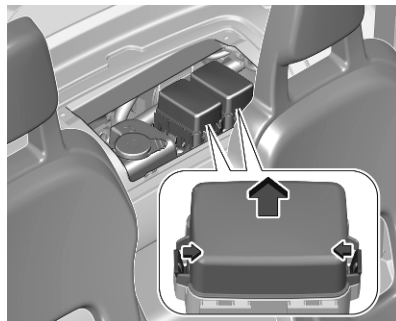

Unclip the access covers of the fuse boxes.

Pull out the blown fuse and replace it.

Fuse box 1

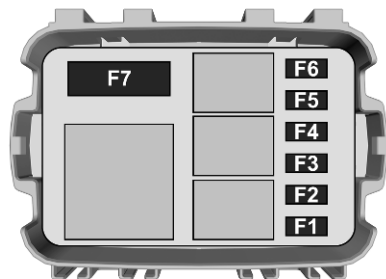

No. Circuit

- 1 Brake switch
- 2 Main computer
- 3 Fan
- 4 Instrument panel
- 5 Battery computer

No. Circuit

- 6 Horn
- 7 Battery drive train / DC / DC converter

Fuse box 2

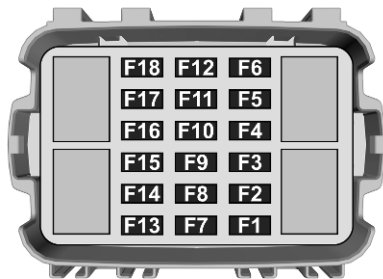

No. Circuit

- 1 Steering mounted control
- 2 Main computer
- 3 Screenwash pump
- 4 -

No. Circuit

- 5 Instrument panel control indicators
- 6 -
- 7 Motor computer
- 8 Brake switch
- 9 USB power outlet / lighting for ventilation / heating / demisting buttons / drive selector
- 10 -
- 11 Diagnostic socket
- 12 Wiper motor
- 13 Rear left wheel speed sensor
- 14 Sidelights front left and rear right / number plate light
- 15 Sidelights rear left and front right
- 16 Right-hand dipped beam headlight

No. Circuit

- 17 Left-hand dipped beam headlight
- 18 Wiper motor

Tyre pressure

The tyre inflation pressures are indicated on a label located on the base of the driver's seat.

Incorrect tyre pressures will impair safety, vehicle handling, comfort and will increase tyre wear.

For the tyres approved for your vehicle, refer to the EEC Certificate of Conformity provided with your vehicle or other national registration documents.

The driver is responsible for correct adjustment of tyre pressure.

Temperature dependency

The tyre pressure depends on the temperature of the tyre. During driving, tyre temperature and pressure increase. Tyre pressure

values provided on the tyre information label are valid for cold tyres, which means at 20 °C.

The pressure increases by nearly 10 kPa for a 10 °C temperature increase. This must be considered when warm tyres are checked.

Wheel changing

The vehicle is not equipped with on-board tools, such as a jack or wheel brace.

In the event of a flat tyre, seek the assistance of a workshop.

To have winter tyres fitted or the wheels changed, consult a dealer or qualified workshop.

Caution

Do not use tyre chains.

Towing the vehicle

Before towing, switch the ignition off and release the parking brake.

Possible ways of towing the vehicle:

- with only the rear wheels on the ground
- with a flatbed
- with a tow bar and all four wheels on the ground

Caution

Do not tow the vehicle with only the front wheels on the ground.

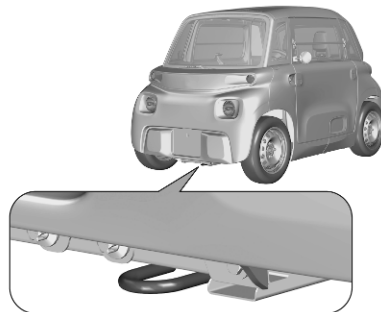

Use the towing eye only to free the vehicle when stuck, or to secure it for recovery on a flatbed lorry or trailer.

Exterior care

Caution

Do not use an automatic car wash or high-pressure cleaning devices.

Lock the doors and windows before cleaning the vehicle.

Do not wash the vehicle in full sunhsine or in extremely cold conditions.

Use a garden hose or a sponge and soapy water to clean the vehicle.

Only use pH-neutral soap.

Recommended fluids and lubricants

Only use products that meet the recommended specifications.

⚠ Warning

Operating materials are hazardous and could be poisonous. Handle with care. Pay attention to information given on the containers.

Washer fluid

Use only washer fluid approved for the vehicle to prevent damage of wiper blades, paintwork, plastic and rubber parts. Consult a workshop.

Brake fluid

Over time, brake fluid absorbs moisture which will reduce braking effectiveness. The brake fluid should therefore be replaced at the specified interval.

Use only DOT4 brake fluid from a sealed container. Consult a workshop.

Identification plate

The identification label is located on the base of the passenger seat.

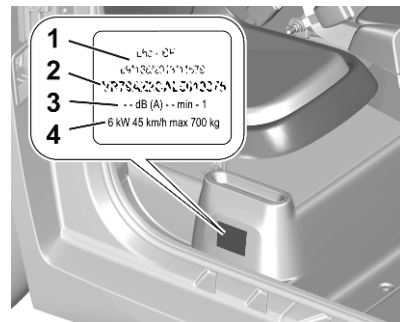

- 1 manufacturer / type approval number
- 2 vehicle identification number
- 3 noise level / rated speed
- 4 maximum power / maximum speed / gross vehicle weight

Vehicle data

Unladen vehicle weight [kg]	471
Gross vehicle weight [kg]	700
Nominal power: EC standard [kW]	6
Maximum power: EC standard [kW]	9.4
High voltage battery capacity [kWh]	5.5
AC charging	230 V (single-phase) / 16 A
Charging cable length [m]	3
Charging time	3 hours for 80%
Driving range [km]	75
Vehicle length [mm]	2410
Vehicle width with two exterior mirrors folded [mm]	1388
Vehicle width with two exterior mirrors [mm]	1541
Vehicle height [mm]	1525
Maximum speed [km/h]	45

Vehicle speed

The following table shows the maximum vehicle speed and the range dependent on the state of charge and the temperature of the high voltage battery.

State of charge	0-10%	10-15%	15-20%	20-35%	35-100%
Range	0-7 km	7-11 km	11-15 km	15-26 km	26-75 km
-20 °C to -10 °C	10 km/h	10 km/h	10 km/h	10 km/h	25 km/h
-10 °C to 0 °C	20 km/h	20 km/h	20 km/h	40 km/h	45 km/h
0 °C to 5 °C	25 km/h	25 km/h	30 km/h	45 km/h	45 km/h
5 °C to 10 °C	30 km/h	32 km/h	45 km/h	45 km/h	45 km/h
10 °C to 45 °C	40 km/h	45 km/h	45 km/h	45 km/h	45 km/h

Declaration of conformity

For the declaration of conformity and other customer information, see online.



www.opel.com

Copyright by Opel Automobile GmbH, Rüsselsheim, Germany.

The information contained in this publication is effective as of the date indicated below. Opel Automobile GmbH reserves the right to make changes to the technical specifications, features and design of the vehicles relative to the information in this publication as well as changes to the publication itself.

Edition: July 2021, Opel Automobile GmbH, Rüsselsheim.

Printed on chlorine-free bleached paper.

ID-OROA0BSE2107-en

